

# IC-30A

UHF FM  
TRANSCEIVER

INSTRUCTION  
MANUAL



## TABLE OF CONTENTS

I.	SPECIFICATION . . . . .	1
II.	INTRODUCTION . . . . .	2
III.	DESCRIPTION . . . . .	5
IV.	INSTALLATION . . . . .	6
V.	CONTROL FUNCTIONS . . . . .	10
VI.	OPERATION . . . . .	14
VII.	THEORY OF OPERATION . . . . .	15
VIII.	MAINTENANCE . . . . .	18
IX.	BLOCK DIAGRAM . . . . .	20
X.	ALIGNMENT CHART . . . . .	21

## SECTION I SPECIFICATIONS

### GENERAL:

Frequency coverage	444.00 – 449.99
Number of Transistors	Transistors . . . . . 40 FET's . . . . . 24
Diodes	Diodes . . . . . 3 IC'S . . . . . 3 Freq. Range . . . . . 440–450 MHz For specifications without retuning $\pm 3$ MHz
Freq. Stability	$1 \times 10E-5$ (0.001%)
Impedance	50 Ohms
Voltage	$13.8V \pm 15\%$
Polarity	Negative Ground
Current	Receiver Squelched . . . . . 250 MA Receiving Signal . . . . . 550 MA TX (10W) . . . . . 2.8 A TX (1W) . . . . . 1.3A
Size	58 x 156 x 244 mm
Weight	2.4 kg
Modulation Type	F3
Antenna Input	50 Ohms
Transmitter:	
Freq. Range	444.00 – 449.99, 22 Channels
RF Power Output	HI . . . . . 10W LOW . . . . . 1W
Maximum Frequency Deviation	Adjustable between 3 to 16 KHz
Audio Input	500 Ohms
Modulation System	Variable reactance phase modulation
Microphone	500 Ohms – Dynamic microphone with push button switch
Crystal Mult. Factor	24
Crystal Range	18 MHz
Spurious Response	-60db or less
RECEIVER:	
Freq. Range	444.00 – 449.99, 22 Channels
Modulation Acceptance	Maximum 16 F-3
I.F. Frequencies	1st – 10.69 MHz 2nd – 455 KHz
20db quieting sensitivity	-4db or less (0db = 1 microvolt)
Bandwidth	$\pm 15$ KHz at the -6db point
Selectivity	$\pm 25$ KHz (-50db) point
Squelch Sensitivity	-80db or less (0db = 1 microvolt)
Spurious Rejection	60db or more
Audio Power Output	1.2W

## **SECTION II – INTRODUCTION**

FM'ers are a proud bunch, and we want you to share that pride. We've got a lot going for us that no other group of hams can equal - - -

- \* Instant communication with other hams on one of the fine repeaters in the area.
- \* No QRM, and no static to interfere with communication.
- \* No distracting tuning when operating mobile.
- \* A unique ability to operate nearly anywhere within a 50 mile circle with low-powered portable equipment.
- \* Neighborhood acceptability because of freedom from TVI and generally un-obtrusive antennas.

These advantages are not gained without a price, however. That price is paid in the form of periodic congestion – how could it be otherwise when the entire group of us try to share usually less than half a dozen carrier frequencies? Such congestion can lead to all sorts of peculiar personal behavior in the form of reaction to the condition. The kind of reaction that we, collectively, exhibit ultimately determines the “personality” of the entire repeater operation. We can have a rigid, military-like operation where nobody ever talks unless there is something of grave significance to say. Or, we can have a continuous 24 hour battle where the strongest station wins in a hostile and friendless contest for the use of the repeater. Somewhat between these two extremes lies a level of legal, courteous, and friendly communications camaraderie that will sustain the kind of operation we all desire. It takes a little work to find that level – – but the work is easy, and it's fun.

FM repeater users have developed some operational habits which are different from traditional practice on the HF bands. While these are not “rules” in any sense of the word, a repeater becomes more satisfying to all who use it if they are followed. Some suggestions about good operating practices are as follows:

### **EMERGENCY TRAFFIC**

Any traffic regarding the safety of life and/or property must take priority over any other use of any repeater. This includes information on accidents, fires, crime, road hazards, and weather information. The usefulness of amateurs in reporting emergencies is one of the primary reasons why the repeater operators are often given access to extremely good locations. Thus, give any station with emergency traffic the right-of-way on the repeater. There is no excuse to either ignore such information or to refuse to telephone the authorities with information from a mobile station. If the city in which the emergency is located is a toll call, just call your local police, sheriff's office, or the Highway Patrol. They will relay the information to the proper authorities.

### **THE REPEATER**

A repeater is a party line or intercom. Every station transmitting is heard by every station listening and there may be several dozen listeners for every talker. Therefore, keep your QSO's short and to the point, especially in the morning and evening when most people are traveling to and from work. Greet your friends, ask your question, make your statement, but then get off! Don't rag chew endlessly and aimlessly for the entire duration of your trip. Don't assume that all listeners want to join your QSO even if you broadcast an invitation to do so.

## CALL SIGNS

Every amateur has a call sign. Present regulations require that this call sign, and at least one call sign of the stations being worked, be sent at the beginning, end, and every ten minutes during the QSO (when transmissions are three minutes or less). Most repeaters timeout in less than three minutes, so no single transmission can be long enough to require three-minute identification. Practices like "Hey Joe," "ya, Sam", may be friendly, but are not legal. Always give your call, then the call of the other station in the first exchange. If you don't know the call of the other stations, identify yourself.

## TEST TRANSMISSIONS

Any piece of equipment, new or old, requires periodic tuneup or checkout. When checking out the transmitter, always start out on a dummy load. There is no reason for test transmission using the antenna unless such a transmission is for loading the transmitter into the antenna or for adjustment of the antenna itself. When this type of transmission must be made, try to make it when the repeater is not heavily used. Also, identify yourself during each transmission and tell why you are making the transmission. If you need help, ask for aid. Keep these test transmissions as short as possible. If you don't have a dummy load (a light bulb makes a very good antenna at UHF) then borrow, buy, or build one.

Momentary transmissions to hear the repeater "squelch tail" are unnecessarily damaging to the many relays used in some repeaters. They have to be replaced often enough under normal use and are expensive. Besides, a repeated series of squelch bursts is annoying to those who monitor continuously and appreciate the silence of FM when no QSO is in progress. If you need to zero your receiver, or to know if you are hitting the repeater, identify yourself and ask for help. You'll get it.

Some do not realize that an FM signal is different from the AM or SSB signals they are used to. For example, **how loud an FM signal sounds is not dependent on the signal strength.** The loudness depends on the deviation of the transmitted signal (in most areas the standard is  $\pm 5\text{KHz}$  to  $\pm 7\text{KHz}$  often called "narrowband"). The signal strength is indicated by the background noise which accompanies the signal. When the signal is full quieting into the receiver, no additional r-f will make any difference. Thus, if the signal is quieting, a 1/2 watt transmitter will sound just as loud as a 1KW transmitter. Just how loud a given deviation will sound is dependent on the audio recovery circuitry in the station receiver. There are still a few receivers in operation which have not been converted from wideband operation ( $\pm 15\text{KHz}$  deviation). On these receivers narrowband signals will not sound very loud. Fortunately all the ham-only equipment, and most of the equipment retired from commercial service is now narrowband or will accept narrowband signals with good audio recovery. If the deviation is too wide for the receiver to accept, either the squelch will "chop" or the signal will sound distorted. Since the frequency of operation of this transceiver is in the UHF Band, a few words about the peculiar characteristic of the "450" band are in order here.

450 MHz is a line of sight frequency. This means that the range of the system will be determined in a large manner by how high the receiving and transmitting antennas are as well as their gain and polarization. Thus for the same system gain the 450 MHz signal will not go as far as say a 144 MHz signal. However, due to the extra gain available in the same physical space (450 MHz antennas are 1/3 as long as 144 MHz antennas), the range for all practical purposes is the same and in some cases better than 144 MHz. Also, in areas of dense buildings the 450 MHz signal bounces from object to object filling in what would otherwise be dead spots at a lower frequency. For example, short tunnels which block VHF signals merely bother UHF signals of the same strength. However, trees with heavy foliage or a lot of water stop UHF cold! (willows, eucalyptus, etc.)

## TECHNICAL

Technical standards of FM are quite different from those of other types of amateur operation. Thus, a brief description of some of these standards follows:

### ANTENNA POLARIZATION:

**FM antennas are vertically polarized.** This is because the quarter-wave whip is a popular mobile antenna, and because non-directional operation is usually desired. However, a horizontal antenna may be used. If the signal received at the repeater or other receiver is strong enough, the quality will be the same. On any direct path there is about a 20db loss between antennas which are cross polarized. On any skip signals the polarization will often be tilted anywhere from vertical to horizontal regardless of the polarization of the originating antenna.

### DEVIATION:

This is how far the modulation swings the carrier from the center frequency. This swing is both positive and negative. Therefore, a signal with  $\pm 5$  KHz deviation at 1 KHz will be 10 KHz wide and a signal with  $\pm 15$  KHz deviation at 1 KHz will be 30 KHz wide. Power levels within the RF portions of the transmitter will have no effect on deviation. Also, only in rare cases will things like shutting off the car engine effect the deviation. The power may vary, but the deviation will remain constant over a relatively large input voltage range. The trend is to narrowband or  $\pm 5$  KHz deviation.

### FREQUENCY STABILITY:

Since most FM equipment is crystal controlled on both transmitting and receiving it is very important to maintain close frequency stability. Since narrowband receivers will tolerate only about 2 KHz frequency drift before the received audio becomes distorted, good frequency stability is a must. Therefore, make sure that your equipment is on frequency and that the crystals are of good quality.

### RECEIVER SENSITIVITY:

In FM, the receiver sensitivity is measured by the 20db quieting method. In this method the audio output of the receiver (at the speaker) is measured with a rectifier type AC voltmeter. An on-frequency signal is then applied through a calibrated attenuator until this voltage reduces to 0.1 of the original value. That point is then the 20db quieting point. On 6 meters this is usually 0.35 microvolt or less, on 2 meters it is usually 0.4 microvolt or less, and on 450 it is 0.6 microvolt or less.

### DUMMY LOADS:

Information on building a suitable dummy load for your FM equipment may be found in any issue of the **ARRL Radio Amateurs Handbook**; or, on page 10.13 of the **VHF-UHF Manual**, published by the RSGB; or on page 37 of the June, 1971 issue of CQ. In the case of low powered portable units running 2 watts or less output, a 47 Ohm or 51 Ohm 2 watt composition resistor makes an excellent load. **Never use a light bulb. It is neither 50 Ohms impedance nor non-radiating.**

### **SECTION III – DESCRIPTION**

This transceiver is extremely rugged and completely solid state. State of the art devices such as Integrated Circuits, Field Effect Transistors, Varactor and Zener Diodes are engineered into a tight knit straightforward electronic design throughout both transmitter, and receiver. Reliability, low current demand, compactness, unexcelled performance and ease of operation are the net result.

The dual conversion receiver with its FET front end and high-Q helicalized cavity resonators boasts low noise and sensitivity of 0.6uv or less. Signal gain of 90db or more is accomplished from the second mixer back by virtue of a 6 stage I.F. amplifier. The need for additional front end RF amplification is thus eliminated. Zener regulated crystal-controlled first and second local oscillators produce unmatched stability. Audio reproduction is of an unusually high order of distortion free clarity.

The transmitter section will produce a minimum of 10 watts RF output. Again, a Zener regulated crystal oscillator is employed for initial frequency stability. Twenty-two crystal controlled channels are provided for operating convenience and versatility. High-Q stages provide minimum interstage spurious response. A low pass filter is placed at the output to further insure undesirable frequency products are not emitted. Final PA transistor protection is incorporated in the final output circuitry.

All RF circuitry is constructed in several plated brass modules which are easily accessible for servicing. The modules are housed in a sturdy brass frame which is, in turn, housed in a rigid metal case providing an extremely durable and rugged unit. Care has been taken to filter and regulate internal DC voltages.

A DC input filter is provided to eliminate alternator or generator "whine" generated in the vehicle environment. Test points are brought up from all major circuits to facilitate maintenance checks and trouble shooting should the necessity arise.

Each unit comes complete with built-in speaker, a high-quality dynamic microphone, mobile mounting bracket, microphone clip, DC cabling and plug, and external speaker plug.

A modern styled face plate, large S meter, small size and low profile design complete the unit's styling. A welcome addition to any dashboard or fixed station.

## SECTION IV – INSTALLATION

### 4-1. Unpacking:

Carefully remove your transceiver from the packing carton and examine it for signs of shipping damage. Should any shipping damage be apparent, notify the delivering carrier or dealer, immediately, stating the full extent of the damage. It is recommended you keep the shipping cartons. In the event storage, moving, or reshipment becomes necessary, they will protect your unit during transportation. Accessory hardware, cables, etc. are packed with the transceiver. Make sure you have not overlooked anything.

- (1) Microphone (dynamic type) . . . . 1
- (2) Microphone hook . . . . . 1
- (3) Power cord . . . . . 1
- (4) Spare fuses (5A) . . . . . 2
- (5) Installing holder A . . . . . 1
- (6) Installing holder B . . . . . 1
- (7) Installing angle joint . . . . . 1
- (8) Gimp nuts . . . . . 4
- (9) Flat washers . . . . . 6
- (10) Plug for speaker . . . . . 1
- (11) Mounting screws . . . . . 2
- (12) Screws for additional bracket . . . 2
- (13) Flat head screw's nuts . . . . . 2
- (14) Acc. plug . . . . . 1
- (15) Mounting screw's nut . . . . . 2



### 4-2. Location:

Where you place the transceiver in your automobile is not critical and should be governed by convenience and accessibility entirely. Since the unit is so compact, many mobile possibilities present themselves. In general, the mobile mounting bracket will provide you with some guide as to placement. Any place where it can be mounted with metal screws, bolts, or pop-rivets will work. For fixed station use, the IC-3PA power supply is designed to be a stand for the transceiver.

### 4-3. Power Requirements:

The transceiver is supplied ready to operate from any regulated 13.5 VDC, 3.0 ampere negative ground source. An automobile 12 volt negative ground system is usually more than adequate. Some attention must be paid, however, to the condition of the vehicle's electrical system. Items such as low battery, worn generator/alternator, poor voltage regulator, etc., will impair operation of your transceiver as well as the vehicle. High noise generation or low voltage delivery can be traced to these deficiencies. If an AC power supply other than the matching IC-3PA is used with your transceiver, make certain it is adequately regulated for both voltage and current. Low voltage while under load will not produce satisfactory results from your transceiver. Receiver gain and transmitter output will be greatly impaired.

**Caution:** Excessive voltage (above 15VDC) will cause damage to your transceiver. Be sure to check the source voltage before plugging in the power cord.



Included with your transceiver is a DC power cable with plug attached. The red wire is positive (+), the black, negative (-). If your mobile installation permits, it is best to connect these directly to the battery terminals. This arrangement eliminates random noise and transient spikes sometimes found springing from automotive accessory wiring. If such an arrangement is not possible, then any convenient B+ lead in the interior of the vehicle and the negative frame can be utilized. Your transceiver provides an internal DC filter that will take out the large amount of transient difficulties anyway. Remember, the unit operates on a negative ground system only – it cannot be used in a positive ground automobile. After making your connections, simply insert the plug into your transceiver.

When your transceiver is mated with its matching AC power supply, the IC-3PA, the power cable from the IC-3PA is simply plugged in the same receptacle in the transceiver and the AC line cord into any convenient wall receptacle. Connect the black ground clip to the neutral wire from the socket used.

#### **4.4. Antenna:**

The most important signal item that will influence the performance of any communication system is the antenna. For that reason, a good, high-quality, gain antenna of 50 Ohms impedance is recommended, fixed or mobile. In UHF as well as the low bands, every watt of ERP, makes some difference. Therefore, 10 watts average output plus 6db of gain antenna equals 40 watts ERP, presuming low VSWR of course. The few dollars investment in a gain type antenna is well worth it.

When adjusting your antenna, whether mobile or fixed, by all means follow the manufacturer's instructions. There are some pitfalls to be aware of. For example, do not attempt to adjust an antenna for lowest VSWR when using a diode VSWR meter not engineered for UHF applications. Such readings will invariably have errors of 40% or more. Rather, use an in line watt meter similar to the Sierra Model 164B with UHF element. Further, when adjusting a mobile antenna, do so with the motor running, preferably above normal idling speed. This will insure proper voltage level to the transceiver.

The RF coaxial connector on the rear chassis mates with a standard PL-259 connector. Some models may have a metric thread. In any event, the RF connector will mate with almost any PL-259 connector if care is taken to seat them properly. In UHF it is wise to use only the highest grade cable available to prevent undue power loss and low sensitivity. RG-58 size cable is the **minimum** and RG-8 polyfoam is standard.

#### **4.5. Microphone:**

A high quality dynamic microphone is supplied with your transceiver. Merely plug it into the proper receptacle on the front panel. Should you wish to use a different microphone, make certain it is of the LOW impedance type; at least 500 Ohms. Particular care should be exercised in wiring also, as the internal electronic switching system is dependant upon it. See the schematic for the proper hookup. Under no circumstances use a "gain pre-amp" type microphone. The audio system in your transceiver is more than adequate and additional pre-amplification unnecessary. To use this class of microphone is to invite distortion.

**4-6. Crystals:**

Your transceiver has 22 channels, both transmit and receive, or total of 44 crystal sockets. The channel selector switch selects one transmit and one receive channel in each of its 22 positions.

To order additional crystals from a manufacturer, the following correlation data is provided. Remember to specify high activity as prerequisite to your acceptance.

**Crystal Data**

Holder Type:	HC-25/u
Calibration Tolerance:	$\pm 0.002\%$ at $25^{\circ}\text{C}$
Temperature Tolerance:	$\pm 0.001\%$ at $-10^{\circ}$ to $+60^{\circ}\text{C}$
Load Capacitance:	20 pF
Effective Resistance:	25 ohms or less
Transmit Crystal:	Crystal Frequency <u>Desired Operating Frequency</u> 24
Receiver Crystal:	Crystal Frequency <u>Desired Operating Frequency - 10.69 MHz</u> 18
Series Tuned 3rd Overtone	
Cut:	"AT" optimum angle $\pm 2$ min.

The amount of frequency spread between any two receiving or any two transmitting frequencies should not exceed 2.5 MHz. Since the receiver and transmitter are independent of each other, you may have any practical amount of frequency separation you wish here. Only two or more widely spaced frequencies for the receiver alone or for the transmitter alone need be considered under the 2.5 MHz limitation.

Trimmers have been placed on the crystal board to assist you in "tweaking" new crystals on frequency. Consult the trimmer location chart (Fig. 2) for their positions.

The amount of frequency spread between any two receiving or any two transmitting frequencies should not exceed 3 MHz. Since the receiver and transmitter are independent of each other, you may have any practical amount of frequency separation you wish here. Only two or more widely spaced frequencies for the receiver alone or for the transmitter alone need be considered under the 3 MHz limitation.

CRYSTAL POSITION CHART (Fig. 2)

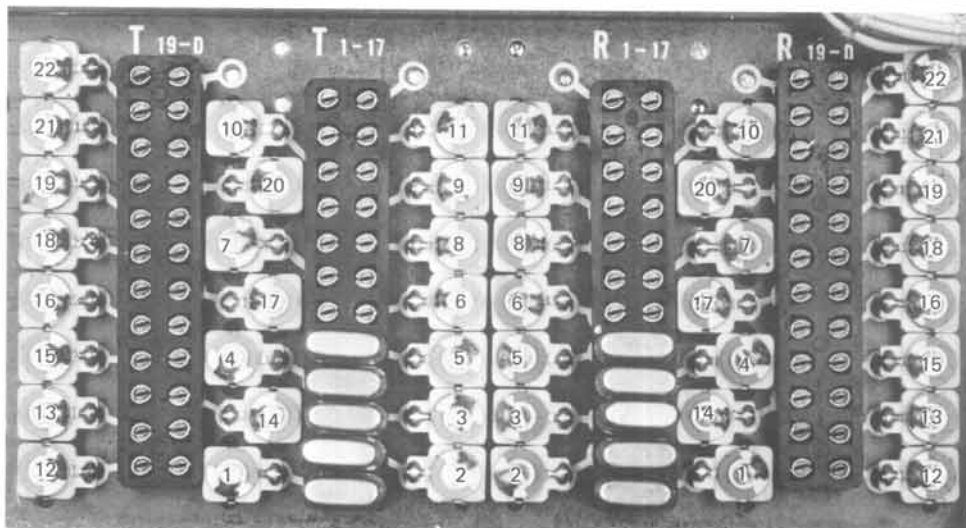

4-7. **External Speaker:**

An external speaker jack and plug is supplied with your unit in the event another speaker is desirable. The external speaker impedance should be 8 Ohms. The use of the external speaker jack will disable the internal speaker. An 8 Ohm headset can be utilized as well. (See Fig. 3).

## SECTION V – CONTROL FUNCTIONS

### 5-1. Front Control and Jacks (Fig. 2)

1. High-Off-Low Switch: Opens or closes the 12 VDC source voltage to the transceiver. "In high" position, output power is 10 watts. "In low" position, output power is 1 watt.
2. Volume Control: Controls audio output level of the receiver.
3. Squelch Control: Controls the squelch threshold point of receiver.
4. Microphone Jack: Accepts 3 prong mike plug supplied on the microphone.
5. S-RF Meter: Reads S signal strength in receive mode and relative RF output in transmit mode.
6. Channel Selector: Selects one of 22 pairs of transmit-receive crystals.
7. C.O.S. Lamp: (Receive indicator)
8. Transmit Indicator:

### 5-2. Rear Panel (Fig. 3)

RF Output Jack: Accepts standard PL-259 coaxial connector. Note: Some transceivers may come with a metric threaded connector. Most PL-259 connectors will mate satisfactorily if care is taken to seat them properly. If you have difficulty, try a different make of PL-259.

External Speaker Jack: This jack mates with the plug supplied for external 8 Ohm speaker or headset use. The use of this jack mutes the internal speaker.

Power Cord: Mates with DC cord plug or power connections of IC-3PA power supply.

Accessory Socket: Center Meter, etc. can be connected at this point.

Identification plate: States model, and serial number.

Part 15 Certification: States the IC-30A meets FCC Part 15 regulation.

Accessory Socket:

1. Discriminator output
8. Ground.

The discriminator output from Pin 1 is used for an indication of the frequency difference between an incoming signal and the receive frequency. A 50 uA center meter is connected to Pin 1 and Pin 8. The other 7 pins may be used for whatever you wish. Some examples might be power supply voltage, audio output, frequency check, remote control, etc.

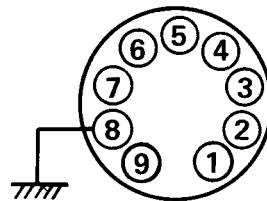

FRONT VIEW (Fig. 3)

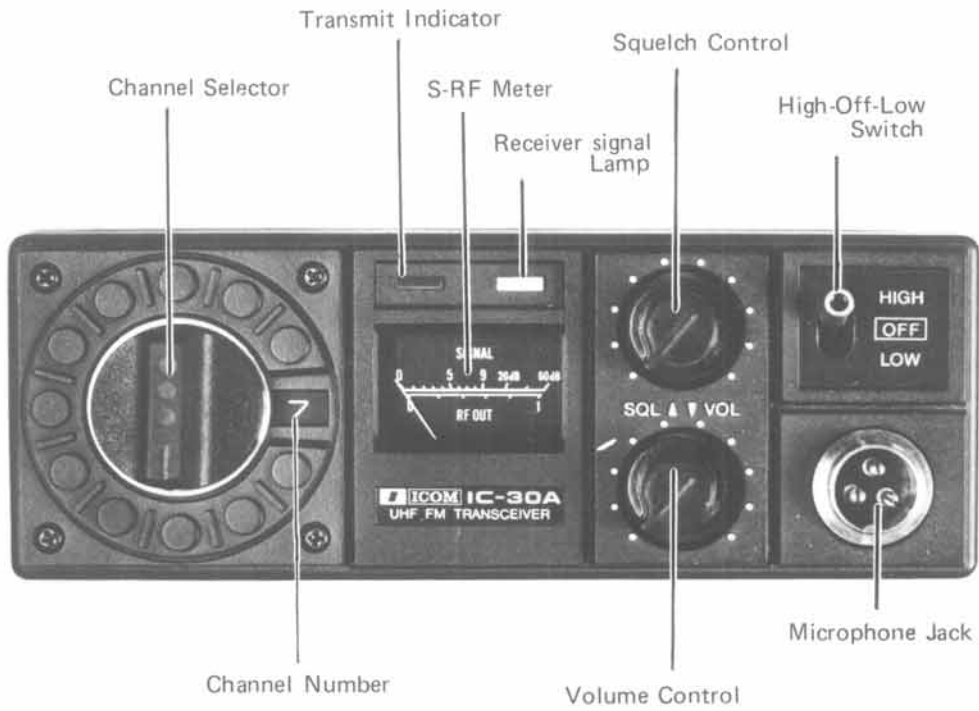

REAR VIEW (Fig. 4)

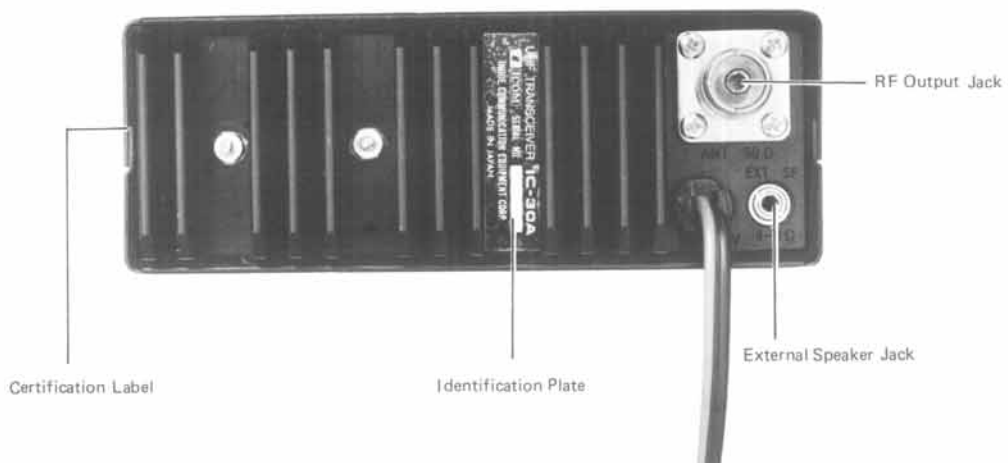

TOP VIEW  
(Fig. 5)

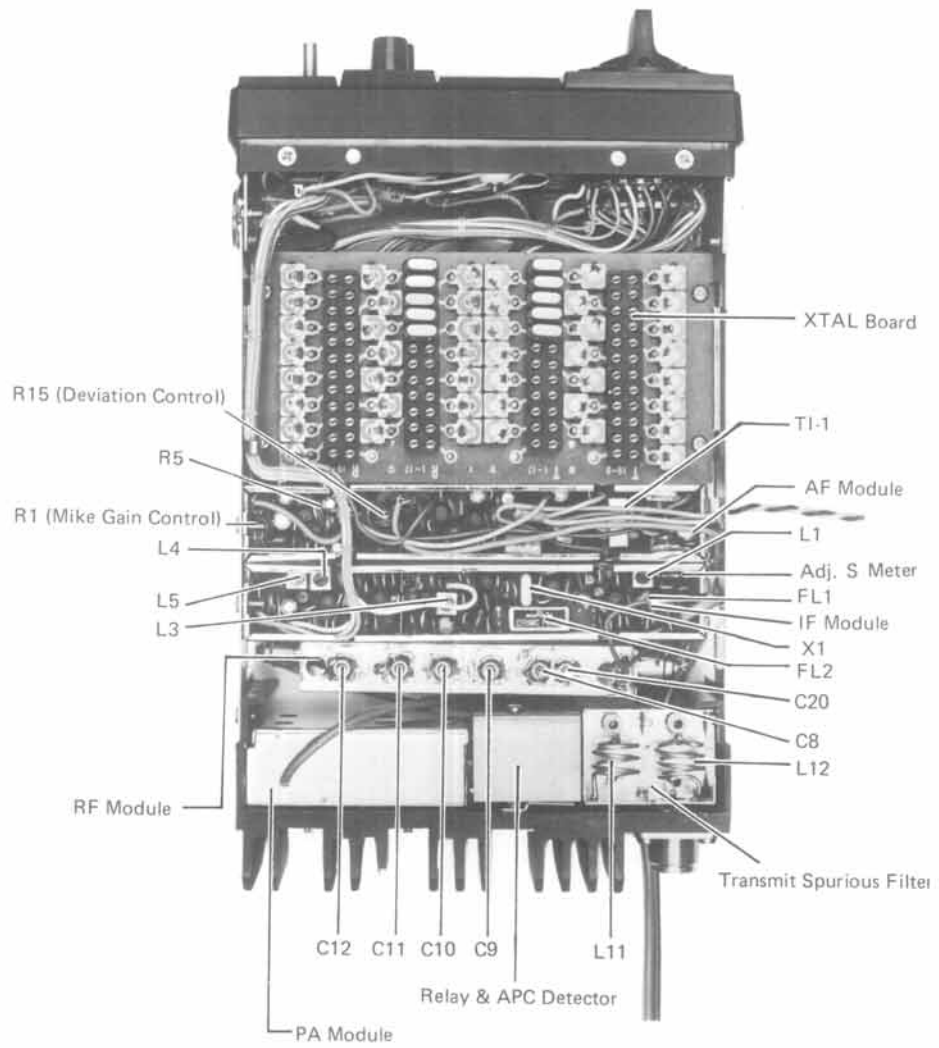

BOTTOM VIEW  
(Fig. 6)

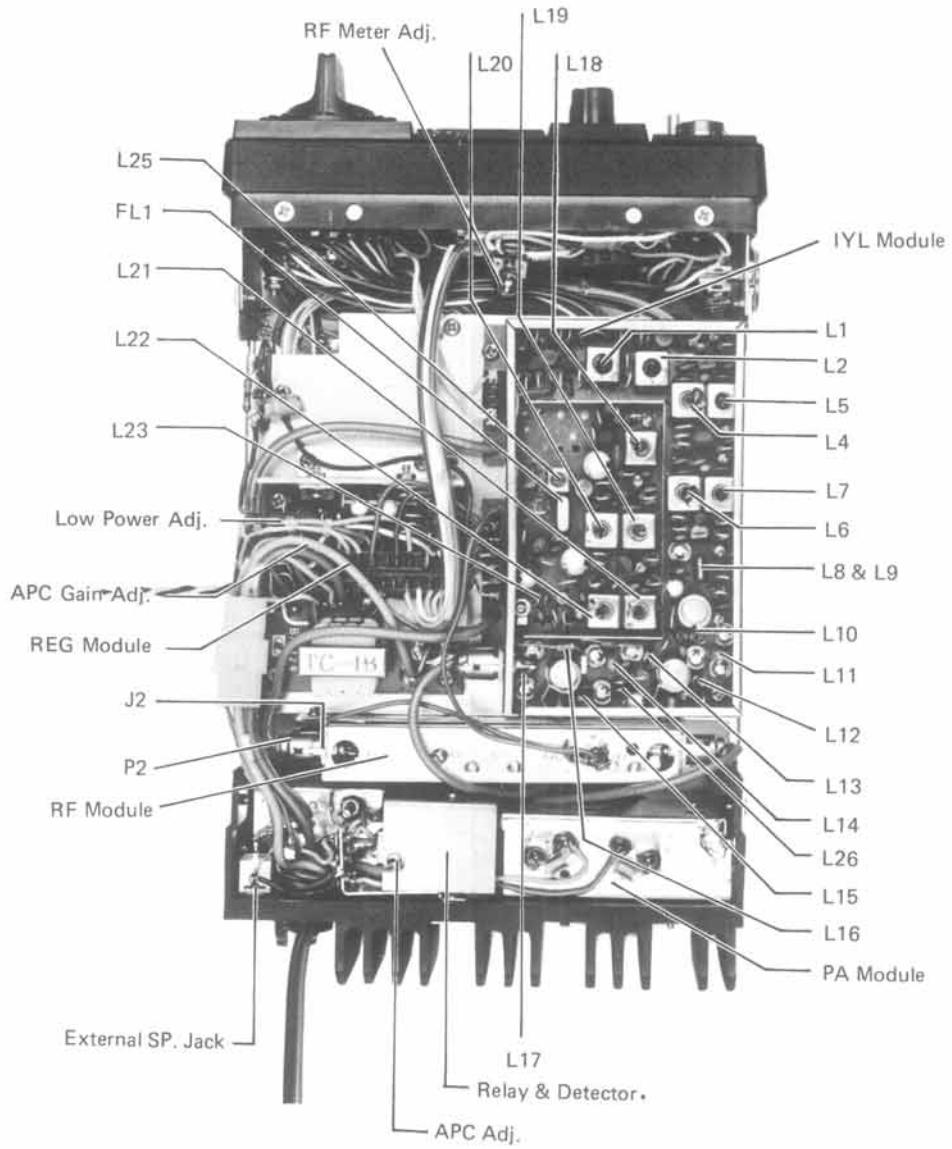

## **SECTION VI – OPERATION**

### **6-1. Initial Preparations:**

- a. Connect the microphone to the microphone jack.
- b. Connect the antenna to the antenna coax connector. Make sure the coax line is of the correct impedance (50 Ohms) and is neither shorted nor open.
- c. Make sure the function switch is in the off position, then connect the power cord to the power supply jack. The red lead should be connected to the positive side of the power source and the black lead to the negative side. In the event that these leads are improperly connected the IC-30A will not function. No damage will be incurred, however, since protection is provided in the IC-30A for this purpose.
- d. Turn the volume and squelch controls to the maximum counter-clockwise position.

### **6-2. Operation:**

- a. When the function switch is set to either the high or low position, the set is switched on and the channel indicator window and meter will be illuminated.
- b. Switch the channel selector to the desired channel.

### **6-3. Reception:**

- a. Adjust the volume control to a comfortable listening level of noise, if no signal is present.
- b. Carefully adjust the squelch control clockwise until the noise just disappears. This is the proper squelch threshold setting and must be done when no signal is present. Your transceiver will now remain silent until an incoming signal is received which opens the squelch. If the squelch is unstable due to the reception of weak or unstable stations, adjust the squelch control further until the proper threshold is obtained.
- c. The S meter indicates the signal strength of the incoming stations and is calibrated in S units, and db over S9.

### **6-4. Transmitting:**

- a. Push the PTT (push to talk) button on the microphone and the transceiver will transmit. At the same time the TX indicator will be illuminated red and the meter will provide an indication of relative power output of the transmitter. The pointer will be on or near the red mark on the meter scale when on high power and just a little over 1 on low power.
- b. Hold the microphone about three inches from your mouth and speak in a normal voice. The microphone is of the dynamic type and provides good pickup for all levels of voice.
- c. To receive again, just release the PTT button. This will also switch off the red TX light.



## **SECTION VII – THEORY OF OPERATION**

### **7-1. Voltage Regulator Module**

The voltage regulator module provides the function of regulating the voltage needed by the IC-30A transceiver.

Also provided is the filtering of the input from the car electrical system, and reverse polarity protection.

In addition to the filtering and voltage regulation the module also provides amplification and control for the VSWR sensor circuit.

Q-1 and Q-3 are pass transistors providing regulated voltage to the receiver and low level transmitter stages. The diodes D-1 and D-3 regulate the voltage at the base of Q-1 and Q-3. R-2 and R-4 provide current limiting for D-1 and D-3. R1 and R3 limit the dissipation of Q-1 and Q-3, R-6, R-7, D-4 R-8 and D-5 are used as over voltage sensors to prevent damage to the finals should excessive voltage be applied.

Q-7 is the switching transistor for the signal light. Q-2 is an inverted switch for T-R switching.

### **7-2. I.Y.L. Module**

The transmitted signal is generated in the crystal oscillator Q-1 (2SC373) and then buffered by Q-2 (2SC373). Q-1 is a modified colpitts oscillator.

The crystal frequency is 1/24th of the desired output frequency and trimmers on the crystal board alter frequency. The buffer transistor Q-2 is transformer coupled to the MV-201 modulation circuit. The modulation circuit is a bridge circuit operating at the crystal frequency. It is composed of the transformer secondary, the varactor diode, and the other components C-8 and R-13. This circuit is unbalanced by the application of audio from the speech amplifier section of the AF module. This circuit unbalance introduces reactance into the circuit which changes the phase delay across this circuit. Resistors provide bias voltage for reverse bias of diode D-2.

The modulated signal is then fed to the base of Q-3. Q-3 has its output tuned to twice the crystal frequency by C-14 and L-4. C-16 and L-5 provide matching and tuning on the same frequency to the base of Q-4 which is a similar doubler, tuned to 4 times the crystal frequency.

The circuit of Q-5, while also a doubler circuit, is operating now in the VHF range and the signal is coupled through an air transformer composed of L-8 and L-9. While L-8 is parallel tuned L-9 is again series tuned into the base of Q-6. Q-6 is a buffer circuit which is used to raise the VHF signal to the proper level to drive Q-7 which is a tripler circuit to generate 450 MHz.

The signal is coupled to Q-7 by C-33 and C-35 while the circuit of C-36 and L-11 lower the base impedance to a level to cause the collector of the previous stage to appear as a parallel tuned circuit.

The output of the Q-7 circuit is at 24 times the crystal frequency and is buffered by Q-8 and fed to the PA module through J-4.

The receiver multiplier stage consists of the crystal oscillator, a doubler and two tripler stages.

The crystal oscillator formed by Q-9 is of the 3rd overtone type operating on 24 MHz. The output of this stage is applied to the base of Q-10 which is connected as a doubler. Q-11 is a tripler tuned to six times the crystal frequency by L-21 and C-63.

Q-12 is the tripler whose output drives the mixer circuit located in the RF module. As such, this circuit must have sufficient power to drive the cable load and the circuit.

The circuit comprised of C-57, L25, R-51, FL-1 and the FET Q-13 is a 10.69 MHz IF filter and amplifier.

### **7-3. Final Amplifier**

The final amplifier module amplifies the signal from the multiplier buffer module and raises the power to the 10 watt area.

The P.A. also includes the RF switching relay, VSWR detector circuits and two helicalized resonators used for filtering both the transmitted signal and the received signal.

The 450 MHz signal is coupled to the PA through P-1 to the matching/tuning network of L-1, L-2, C-1, C-2, C-29 to the base of Q-1 where the signal is amplified. R-1 and L-3 maintain Q-1 in the proper class of operation. The signal from Q-1 is fed through matching network L-6, C-7, C-8, to power amplifier Q-2 where the signal is boosted to 10 watts or more. This signal is then fed through L-10, C-12, C-13, C-14 of the Pwd/Pref coupler thus through relay RL-1 to the filter consisting of C-22, L-11 & C-23, L-12 to output jack J-1.

The following components are bypasses or RF chokes:

C-3, C-4, C-5, L-4, L-5, C-9, C-10, C-11, L-8, L-9, C-15, C-16, C-18, C-19, C-20, C-21, C-25  
C-26, C-27

The directional coupler consists of R-4, D-1, C-28 for reflected and D-2, C-27, R-3 for forward. The coupler itself is printed and etched on the PC board. VSWR information from the coupler is fed to the REG module.

P2 feeds signal to the RF module in the RX mode.

**7-4. Receiver RF Amp. & First Mixer**

The input signal is amplified by the field effect transistor Q-1 (3SK48) and passed into the RF filter. This filter is a high Q helicalized resonator with excellent bandpass characteristics and shockproof construction. From the output of the helicalized resonators the signal is fed to the gate of the first mixer. Q-2 (2SC1070) where it is mixed with the output from the I.Y.L. which is fed into the base of Q-2 to obtain the 10.69 MHz. IF signal. The output of the mixer is fed through L-7 to the I.F. amplifier. The FET transistors in the receiver RF unit have the highest possible sensitivity and signal to noise ratio and the lowest possible cross modulation.

**7-5. Receiver 10.69 MHz I.F. Amplifier, 2nd I.F. amplifier, Limiter and Discriminator Module.**

The 10.69 MHz signal L-7 in the RF unit is amplified by Q1 (2SC372) and fed to the gate of the 2nd Mixer Q2 (2SK19) through the 1st ceramic filter FL 1 (SFE 10.7 MA). The variable resistor in the emitter circuit of the First IF transistor Q1 adjusts the IF gain and S-meter sensitivity. The 2nd Oscillator Q9 (2SC372) is crystal controlled and operates on 10.245 MHz. The output is taken from the emitter of Q9 and fed into the gate of the 2nd Mixer (2SK19) to obtain the 455 KHz. IF signal, which is passed through the 2nd ceramic filter FL2 (CFM455C) and amplified by Q3, Q4, Q5, Q6, Q7 and Q8 (2SC372s). The output of Q8 is then demodulated in the discriminator circuit, consisting of L4 (LS-14), L5 (LS-15), and D7 and D8 (1N60s).

**7-6. Receiver Audio Amplifier, Squelch, and Speech Amplifier (Module U-4-3)**

The output of the discriminator drives two circuits: the audio amplifier, and the squelch. The audio signal, after being adjusted by the volume control R-1, is then fed to Q8 and Q9 (2SC372 and 2SC373), followed by the audio power amplifier stage Q10 and Q11 (2SD235s), which gives an audio output of 1.5 Watts. The squelch circuit is driven by the noise present in the output of the discriminator when no carrier exists. The noise is amplified by transistors Q5 and Q6 (2SC372s), and rectified by the diodes D3 and D5 (1N60s). D4 (1S1555) temperature compensates Q7's squelch operation switching level. The resulting DC voltage is used to forward bias Q7 (2SC373), which becomes conductive, reducing the voltage on the base of the Q9 preamplifier resulting in silencing of the audio amplifier. When a carrier is present in the antenna, the noise in the 455 KHz IF decreases due to the quieting action of the limiter. In turn reducing the output from the squelch detector, and causes Q7 (2SC373) to stop conducting, thereby allowing the Q9 preamplifier and audio power amplifier to perform normally. The squelch is adjusted to choose the amount of DC required to cut off Q7.

The signal from the microphone is amplified by Q1 and Q2 (2SC372s), fed to the deviation limiter, which consists of D1 and D2 (2S2473s), and the active audio filter Q3 (2SC372), and further amplified by Q4 (2SK30) before being fed to the modulation circuit in the transmitter oscillator unit.

## **SECTION VIII — MAINTENANCE**

**8-0.** The necessity of completely realigning the unit is unlikely. The most common cause of breakdown is component failure. Great care and precision are employed in manufacturing and warranty service is provided to ensure that it meets specifications. Adjustments not outlined herein should not be undertaken unless the owner is skilled in UHF techniques.

**8-1. Transmitter Alignment:**

a. Remove the two retaining screws on the top and bottom of the cabinet and the two screws at the rear of the cabinet. Separate the chassis from the cabinet.

b. Connect a dummy load (50 Ohms) or a watt meter to a coax connector. (Fig. 3).

c. Connect the power supply cord to the power jack (Fig. 3) and the microphone to the microphone jack (Fig. 3).

d. To align the transmitter on a desired frequency, switch the channel control to the desired channel. Slowly adjust the trimmer capacitor for that channel until the desired frequency is achieved. Consult Fig. 1 for the location of the proper trimmer. These trimmers should be adjusted very slowly, while the transmit frequency is observed on suitable measuring equipment. This can be accomplished by connecting a 50 microampere center "O" meter. Install the meter at the accessory socket pin 8, and ground. With the meter connected in the receive mode on the channel desired, adjust the trimmer capacitor for the null point on the meter. Another IC-30A equipped with a discriminator meter can serve this purpose.

e. The Multipliers, driver and power output stages should be aligned on LOW power first then set the function switch on HIGH power. Align these stages by peaking each check point for maximum excursion from zero. Some points may be negative.

Be careful not to transmit for more than 5 seconds during each alignment step, as damage could be caused to the transistors due to overloading during this procedure. It is highly recommended that a spectrum analyzer be used if any transmitter stages are adjusted.

**8-2. Receiver frequency alignment and netting without instruments.**

Connect the zero center 50 microamp meter to the number 1 and 8 pins of the accessory socket. While receiving stations on the desired channel known to be on frequency, adjust receive crystal trimmer capacitor for zero indication on the meter.

**8-3. Receiver Alignment:**

- a. Remove the microphone from the transceiver to prevent accidental transmission during receiver alignment.
- b. Allow the test oscillator or generator to stabilize.
- c. Connect the test oscillator or generator to the antenna coax connector. Set the test oscillator or generator to the desired frequency. Set the squelch control to the maximum counter-clockwise position.
- d. Align the receiver according to the chart provided. (See Chart 1.)
- e. When setting the receiver to a desired frequency, a discriminator meter should be connected to ACC pins 1 and 8 and the receiver trimmer capacitor adjusted to cause the S meter to read maximum and the discriminator meter to read zero. Refer to Fig. 1 for the location of the proper trimmer corresponding to the channel to be used. Adjust these trimmers very slowly while observing the discriminator meter. Another IC-30A operating on the desired frequency can be used for this purpose also.

**PLEASE NOTE:**

The equipment has been carefully aligned with accurate equipment, including a spectrum analyzer to reduce spurious radiation.

Do not adjust, replace parts, or perform any type of maintenance unless you are fully qualified to do so!!

# SECTION IX – BLOCK DIAGRAM

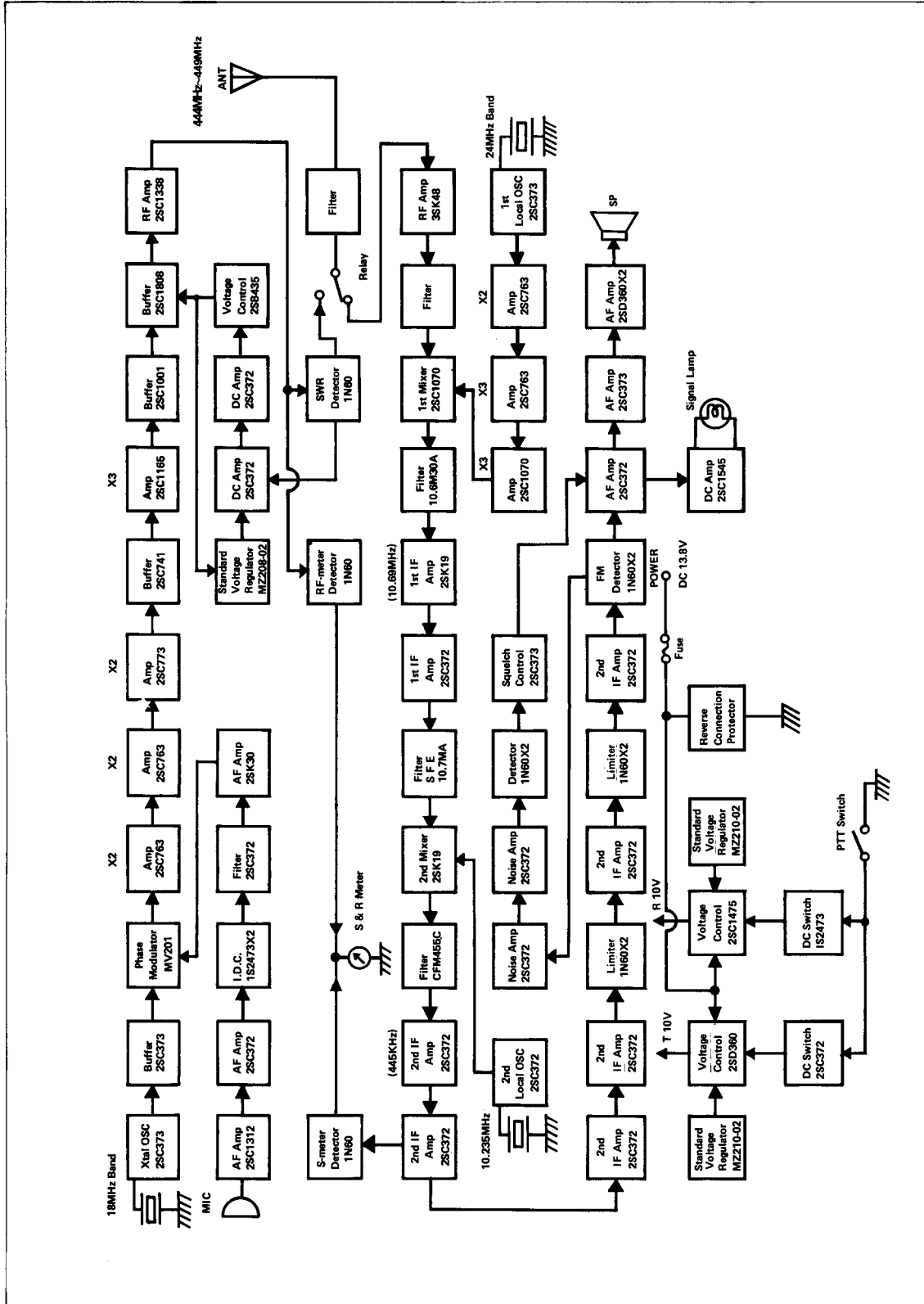

**SECTION X - ALIGNMENT CHART IC-30A VOLTAGE CHART**

MODULE	NO.	NAME	BASE	EMITTER	COLLECTOR	DRAIN	NOTES
RF	Q1	3SK48	0 (G 1)	0.2 (S)	0.2 (S)	9.6	R
RF	Q2	2SC1070	1.0	0.3	9.3		R
IF	Q1	2SC372	4.0	3.2	9.0		R
IF	Q2	2SK19	0 (G)		1.3	8.4	R
IF	Q3	2SC372	0.6	0	3.2		R
IF	Q4	2SC372	6.5	6.0	7.0		R
IF	Q5	2SC372	0.6	0	1.0		R
IF	Q6	2SC372	3.4	2.8	4.0		R
IF	Q7	2SC372	6.0	5.8	6.6		R
IF	Q8	2SC372	2.0	1.5	5.5		R
IF	Q9	2SC372	2.5	2.6	9.0		R
AF	Q1	2SC1312	0.2	0.1	2.2		T
AF	Q2	2SC372	2.2	1.5	5.6		T
AF	Q3	2SC372	8.0	7.4	9.5		T
AF	Q4	2SK30A	0 (G)		0.2 (S)	3.2	T
AF	Q5	2SC372	1.5	0.8	9.8		R
AF	Q6	2SC372	1.5	0.7	6.0		R
AF	Q7	2SC373	0.3	0	6.0		R
AF	Q8	2SC372	0.6	0.005	1.3		R
AF	Q9	2SC373	1.3	0.7	12.5		R
AF	Q10	2SD235	0.7	6.5	13.5		R
AF	Q11	2SD235	0.5	0	6.5		R
IYL	Q1	2SC373	3.0	2.4	6.9		T
IYL	Q2	2SC373	3.0	2.7	9.0		T
IYL	Q3	2SC763	1.4	0.9	9.0		T
IYL	Q4	2SC763	1.0	.0	9.3		T
IYL	Q5	2SC773	0.8	0.7	9.2		T
IYL	Q6	2SC741	0	0.3	9.3		T
IYL	Q7	2SC1165	0	0.8	9.4		T
IYL	Q8	2SC1001	0	0	9.5		T
IYL	Q9	2SC373	2.0	1.5	8.6		T
IYL	Q10	2SC763	1.4	0.9	9.0		T
IYL	Q11	2SC763	1.4	1.2	9.4		R
IYL	Q12	2SC1070	1.2	0.6	8.9		R
IYL	Q13	2SK19	0		0.9 (S)	9.4	R
PA	Q1	2SC1808	0	0	12.5		T
PA	Q2	2SC1338	0	0	13.0		T
REG	Q1	2SD360	9.8	10.5	12.0		T
REG	Q2	2SC372	0	10.5	0		T
REG	Q3	2SC1475	10.5	12.5	9.8		R
REG	Q4	2SC372	0.2	0.7	0		T
REG	Q5	2SC372	0.7	0.1	0		T
REG	Q6	2SB435	12.0	13.0	13.0		T
REG	Q7	2SC1545	0.2	13.0	0		T



INOUE COMMUNICATION EQUIPMENT CORPORATION  
NO 6-19, 1 CHOME, KAMIKURATSUKURI, HIRANO-KU  
OSAKA JAPAN